

## Power Amplifier

A power amplifier is an electronic amplifier designed to increase the magnitude of power of a given input signal. The power of the input signal is increased to a level high enough to drive loads of output devices like speakers, headphones, RF transmitters etc. Unlike voltage/current amplifiers, a power amplifier is designed to drive loads directly and is used as a final block in an amplifier chain.

The input signal to a power amplifier needs to be above a certain threshold. So, instead of directly passing the raw audio/RF signal to the power amplifier, it is first pre-amplified using current/voltage amplifiers and is sent as input to the power amp after making necessary modifications. You can observe the block diagram of an audio amplifier and the usage of power amplifier below.

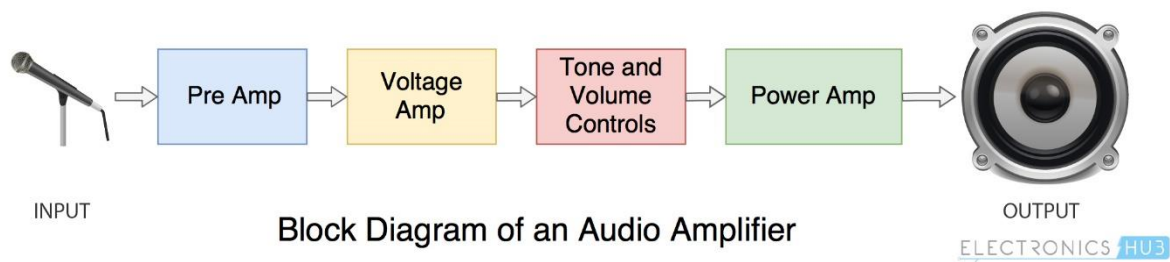

In this case, a microphone is used as an input source. The magnitude of signal from the microphone is not enough for the power amplifier. So, first it is pre-amplified, where its voltage and current are increased slightly. Then the signal is passed through a tone and volume control circuit, which makes aesthetic adjustments to the audio waveform. Finally, the signal is passed through a power amplifier and the output from power amp is fed to a speaker.

## Amplifier Class

There are multiple ways of designing a power amplifier circuit. The operation and output characteristics of each of the circuit configurations differs from one another.

To differentiate the characteristics and behavior of different power amplifier circuits, Power Amplifier Classes are used in which, letter symbols are assigned to identify the method of operation.

They are broadly classified into two categories. Power amplifiers designed to amplify analog signals come under A, B, AB or C category. Power amplifiers designed to amplify Pulse Width Modulated (PWM) digital signals come under D, E, F etc. The most commonly used

power amplifiers are the ones used in audio amplifier circuits and they come under classes A, B, AB or C

Typically, a car amplifier works by taking the 12-volt DC power coming into the amp, turning it into AC, and increasing the voltage via a transformer. Then it combines that high-voltage power with the audio signal coming from the stereo to create a high-voltage, high-current output version of that weak input signal.

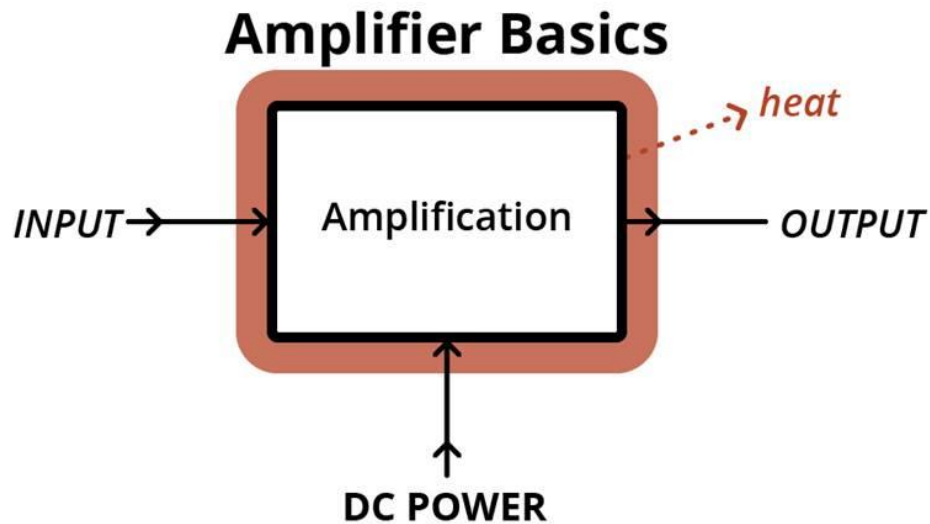

**Amplifier Class** is the system for combining power and signal. Amp class differs from amp to amp with efficiency and sound fidelity dependent on which design gets used. In all designs, banks of output transistors, each a little amp by itself, add their collective power together to provide the amplifier's final output.



The inside of a [Rockford Fosgate T500-1bdCP](#) showing the transformer (the coil of red and green wires) and output transistors (black rectangles glued to the heatsink with white thermal paste).

### **Heat is the enemy**

Amplifiers always put out less power than they consume. An amplifier's efficiency is the ratio of what it puts out divided by what it draws from the electrical system. No amp is 100% efficient, putting out exactly what it draws, nor can an amp put out more power than it draws. The power that doesn't make it to the output terminals is wasted energy that turns into heat. Too much heat will destroy the amplifier's output signal and internal components.

The different amplifier classes produce different amounts of heat. See each class description below.

---

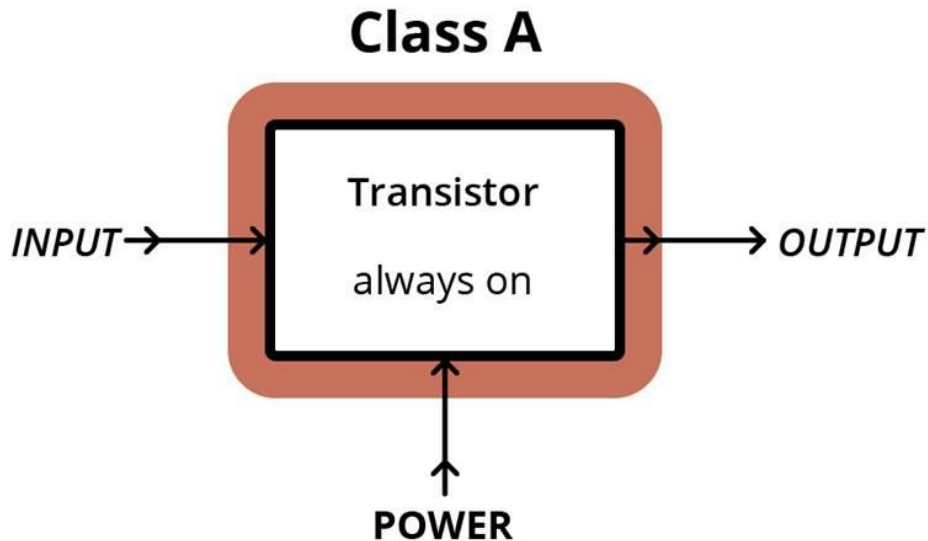

### **Class A amplifiers — the high-fidelity heat source**

A Class A amplifier's output transistors run with "constant bias," meaning they always run at full power whether there's an input signal or not. When there's no signal, the transistors' power turns into heat. When there is a signal, the power goes out the speaker terminals. Also, each Class A output transistor amplifies both the negative voltage and the positive voltage parts of the signal's AC waveform, adding to the workload and generating more heat. Class A amps usually operate around a 25% efficiency level. That means that 75% of their power is turned into heat.

### **Highest fidelity amplifier Class**

Because each output stage transistor is always on, there's no turn-on, turn-off, warming, or cooling cycles affecting the signal flow. In fact, the transistors perform in their most linear fashion, distortion-free, under this condition. And because there're no switching going on, there's no induced high-frequency interference either. Pure Class A amplifiers are rare, expensive, and never used in car audio.

---

## Class B

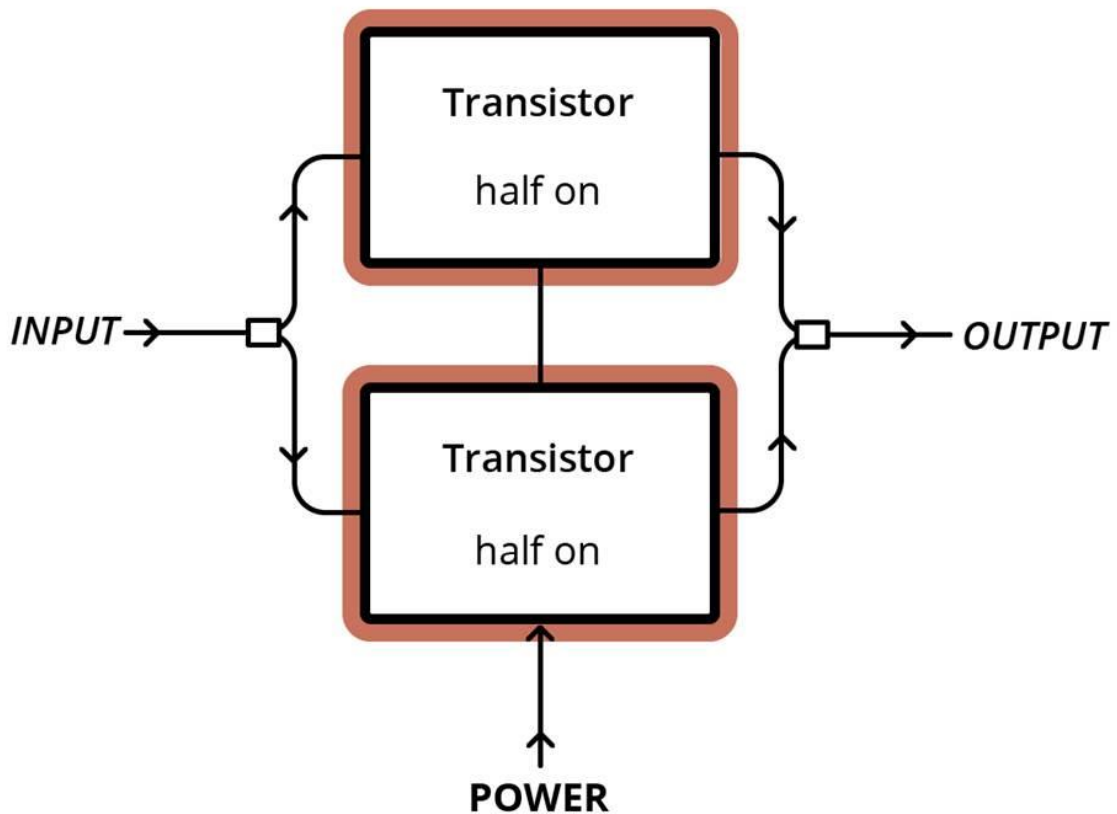

### Class B amps — the two transistor solution

Class B amplifiers lighten the workload of each output stage by replacing the single transistor there with two transistors set up in what is called a "push-pull" arrangement. One transistor amplifies the negative voltage parts of the signal's AC waveform and the other takes care of the positive voltage, and then the two are combined into a unified output. Each transistor is on half the time and off the other half.

#### Efficient with low fidelity

Class B amplifiers are much more efficient than Class A amps — 50% or so — but produce distortion as the two transistors switch on and off. This "crossover distortion" is so bad that very few if any manufacturers offer or produce an amplifier of pure Class B design.

---

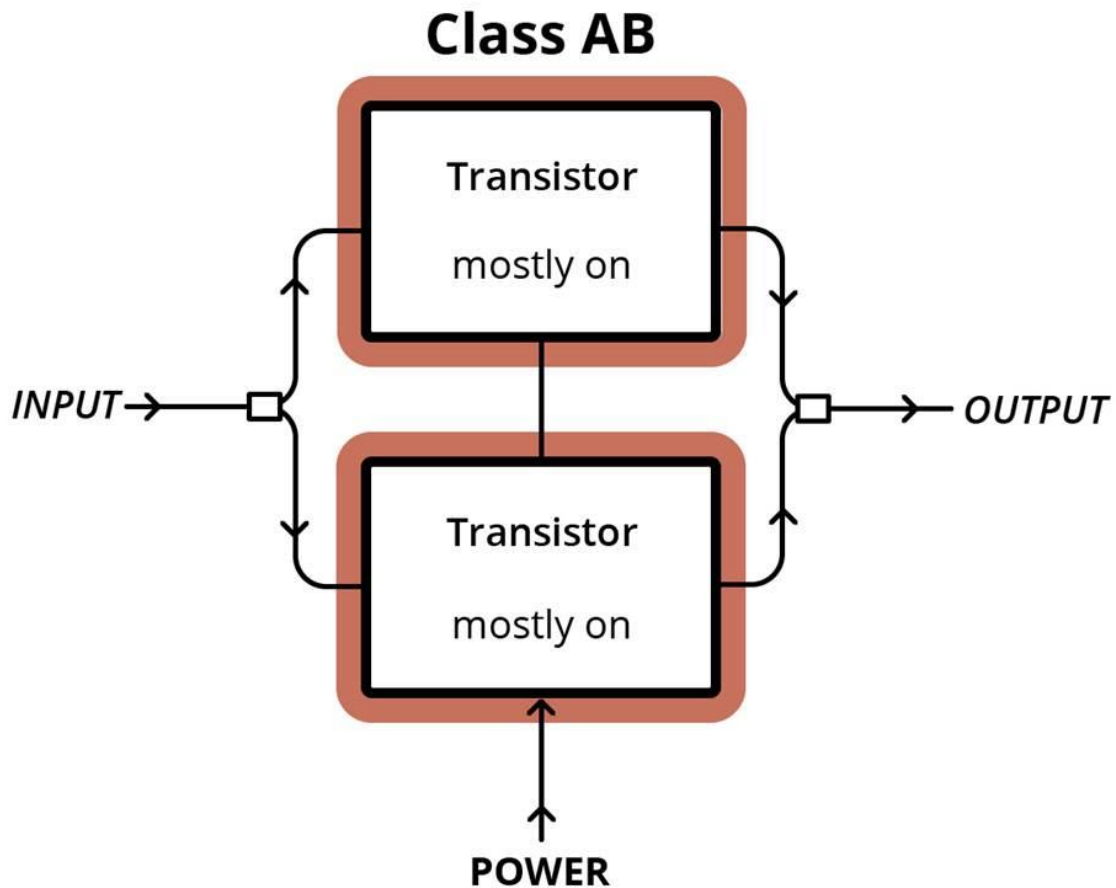

### **Class AB amplifiers — higher fidelity *and* efficiency**

The push-pull pair of output transistors in a Class AB amp are each on more than half the time, and they don't turn on and off suddenly either. This gives the amp the characteristics of a Class A amp when the signal's at low power and conducting through both transistors, and a Class B amp when the power is high. For each amp, there's an optimum bias current, the amount of time when both transistors are passing current, that minimizes the crossover distortion of Class B design.

### **Class AB amps are everywhere**

The result of this design is that Class AB amplifiers have much higher efficiency than Class A amps, up to about 60%, and much less distortion than Class B amps. Most home theater and stereo amplifiers are Class AB.

Until recently, using an AB amp was the only practical choice for attaining high-fidelity, full-range amplification, but now Class D amps are being built that are just as accurate. (Class A is still the winner for accuracy, though.)

---

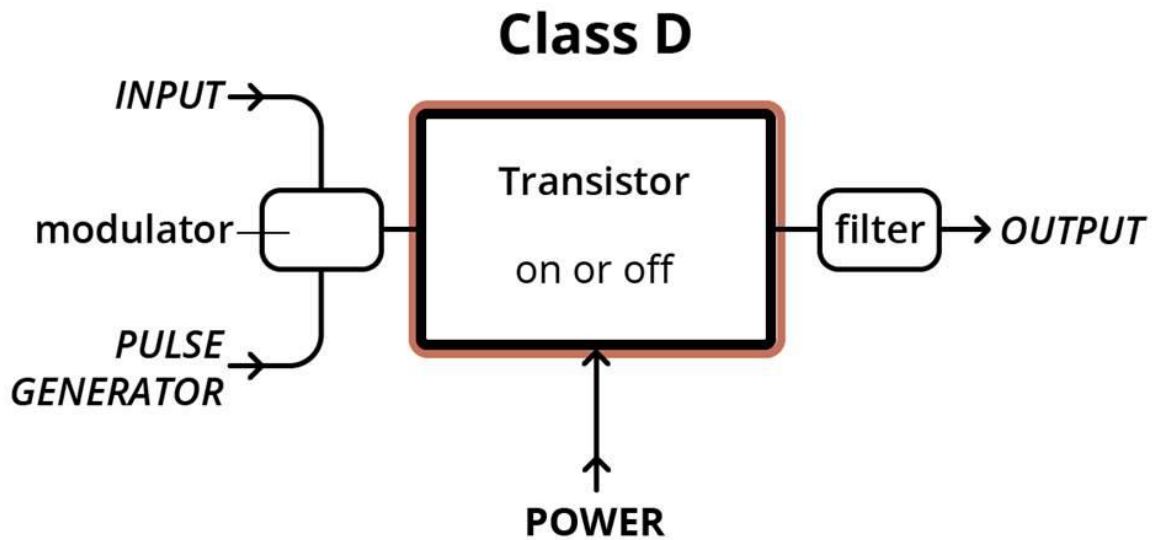

### **Class D amplifiers — popular kings of efficiency**

Class D amplifiers operate in a unique fashion. Onboard circuitry creates very high-frequency (often over 100K Hz) pulses of DC current. The width of each pulse is then modified by the input signal — the wider the pulse, the louder the signal. This is called "pulse width modulation" or PWM. These DC pulses are run through the amplifying output transistors creating the high-power output. Because they are getting DC pulses, not analog signals, the transistors, also called MOSFETs, are either on full power or off with no power. This is the most efficient way of running these transistors — as much as 90% efficient in some cases.

### **D does not stand for digital**

Although making a signal by rapidly switching transistors on and off resembles digital processing that uses zeros and ones, Class D amplifiers are not digital devices. Some of them might have digital control circuits, but the amplifier circuits will be strictly analog.

### **Less-than-highest fidelity**

After amplification, a low-pass filter smooths the output signal so the amp won't put out pulses of power but rather, a continuous analog power output. It also removes the interference generated by those high-frequency DC pulses. Because of this, most audiophiles won't use Class D amplifiers in their systems, citing that need for filtering out generated distortion.

### **Class D has become the go-to choice**

On the other hand, in professional PA systems and car audio applications where perfect fidelity isn't as important, Class D amplifiers have become much more popular because they're smaller, lighter, and run cooler than the other Classes of amplifiers with the same amount of power. And these are big advantages when you have to fit an amp in a vehicle or carry one around for gigs.

---

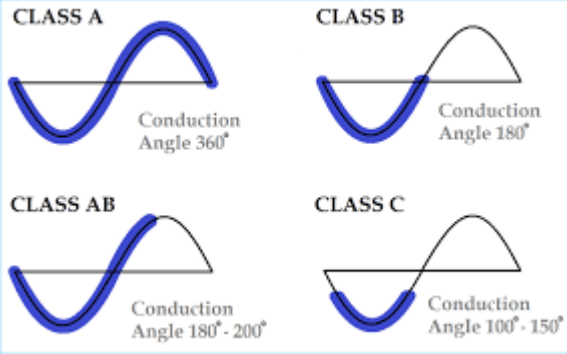

Class	A	B	C	AB
Conduction Angle	$360^\circ$	$180^\circ$	Less than $90^\circ$	$180$ to $360^\circ$
Position of the Q-point	Centre Point of the Load Line	Exactly on the X-axis	Below the X-axis	In between the X-axis and the Centre Load Line
Overall Efficiency	Poor 25 to 30%	Better 70 to 80%	Higher than 80%	Better than A but less than B 50 to 70%
Signal Distortion	None if Correctly Biased	At the X-axis Crossover Point	Large Amounts	Small Amounts